

# Machine control : governor/turbine IEEEG3

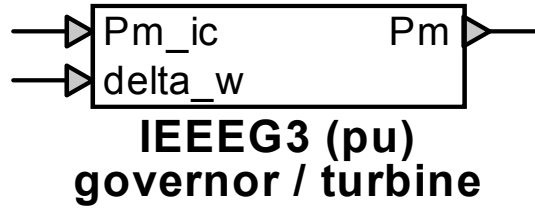

Machine control : governor/turbine IEEEG3 pu .....	1
1 Description .....	1
1.1 Pins.....	1
1.2 Parameters .....	1
1.3 Input.....	2
1.4 Output.....	2
1.5 Representation .....	2

## 1 Description

This device is an implementation of an IEEE Type 3 turbine and governor system similar to PSS/E's IEEEG3 turbine/governor model. This version of the model interprets all input and output values in physical units. For a version with input and output in per-unit quantities, use the device "turbine/governor IEEEG3 pu".

### 1.1 Pins

This device has three pins:

<i>pin</i>	<i>type</i>	<i>description</i>	<i>units</i>
Pm_ic	input pin	mechanical power at t=0	W
delta_w	input pin	speed deviation	rad/s
Pm	output pin	mechanical power	W

### 1.2 Parameters

The value of the following parameters must be defined:

<i>parameter</i>	<i>description</i>	<i>units</i>
Tg	time constant (lag) of gate	s
Tp	time constant (lag) of pilot	s
Tr	time constant (lead) of transient droop	s
Tw	time constant (lag) of water inertia	s
g_vel_open	maximum speed of gate opening	pu(S_base)/s
g_vel_close	minimum speed of gate closing	pu(S_base)/s
g_pos_max	position of gate at Pmax	pu(S_base)
g_pos_min	position of gate at Pmin	pu(S_base)

sigma	coefficient of permanent droop		(value based on pu speed)
delta	coefficient of transient droop		(value based on pu speed)
a11	coefficient of turbine		
a13	coefficient of turbine		
a21	coefficient of turbine		
a23	coefficient of turbine		
S_base	machine VA base	VA	
omega_base	angular speed base	rad/s	

### 1.3 Input

The input pins may be connected to any control signals.

The following inputs are available:

<i>input</i>	<i>description</i>	<i>units</i>
Pm_ic	mechanical power at t=0	W
delta_w	speed deviation	rad/s

### 1.4 Output

The output value is the calculated mechanical power, in physical units.

<i>output</i>	<i>description</i>	<i>units</i>
Pm	mechanical power	W

### 1.5 Representation

The implementation of the model can be inspected by opening the device's subcircuit.

The model uses a unit-conversion shell surrounding the per-unit version of this exciter.

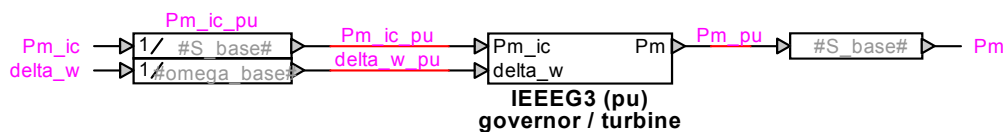

The model is self-initializing at t=0.

The dynamic representation of the model is the following:

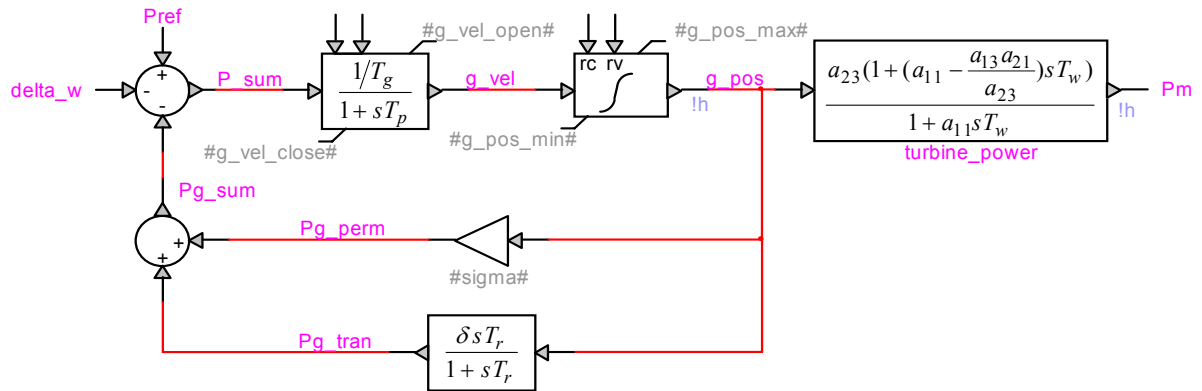

with the value of  $P_{ref}$  calculated to produce  $P_m = P_{m\_ic}$  at  $t=0$ .

The internal signals are:

<i>signal</i>	<i>description</i>	<i>units</i>
P_sum	power error	pu(S_base)
g_vel	gate speed	pu(S_base)/s
g_pos	gate position	pu(S_base)
Pg_perm	permanent droop	pu(S_base)
Pg_tran	transient droop	pu(S_base)
Pg_sum	total droop	pu(S_base)