

Controlled voltage source

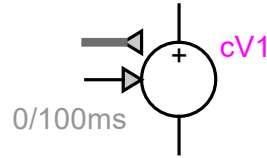

Controlled voltage source device	1
1 Description	1
1.1 Parameters	1
1.1.1 Netlist format	2
2 Steady-state model	2
3 Frequency Scan model	2
4 Time-domain model	2
4.1 Initialization	2

Jean Mahseredjian, 5/18/2022 8:28 AM

1 Description

This device accepts only 1-phase signals.

1.1 Parameters

The device pins are:

- k the positive power pin
- m the negative power pin
- in the control input pin
- B1 the control output bundle (also called bus) pin that can contain observe signal pins

The model parameters are:

- t_{start} start time, if $t < t_{start}$ the source is a short-circuit.
- t_{stop} stop time, if $t > t_{stop}$ the source is a short-circuit. The stop time must be greater than the start time
- Extrapolate Extrapolation option (see below).

Since there is a time-step delay between the control signal setting and the electrical network solution with the determined current value, extrapolation can be used to compensate for this delay. Extrapolation allows to make a prediction based on previous solutions. The "Linear extrapolation" is applied using the previous solution points. The "Error correction" method simply predicts the solution using the previous time-point error.

1.1.1 Netlist format

```
_cV;cV1;6;6;s1,s2,scontrol,bundle_v,bundle_i,bundle_p,  
0,100ms,?v,?i,?p,>v,>i,>p,
```

Field	Description
cV	Part name
cV1	Instance name, any name.
6	Total number of pins
6	Number of pins given in this data section
s1	Signal name connected to k-pin (positive), any name
s2	Signal name connected to m-pin, any name
scontrol	Signal name connected to the control input pin
bundle_v	Signal name connected to the control output pin for observing voltage, optional
bundle_i	Signal name connected to the control output pin for observing current, optional
bundle_p	Signal name connected to the control output pin for observing power, optional
t _{start}	Start time
t _{stop}	Stop time
extrapolate	Extrapolation option: 0 means no extrapolation, 1 means Linear extrapolation, 2 means Error correction
?v	Request for voltage scope, sent to scope group vb (branch voltages), optional
?i	Request for current scope, sent to scope group ib (branch currents), optional
?p	Request for power scope, sent to scope group p (branch power), optional
>v	Request for voltage observe, optional
>i	Request for current observe, optional
>p	Request for power observe, optional

None of the device pins can be deleted.

2 Steady-state model

The steady-state model of this device is a short-circuit

3 Frequency Scan model

The frequency scan model of this device is a short-circuit.

4 Time-domain model

The device output waveform is imposed by the control signal connected to its control input pin.

The source is active (not a short-circuit) for $t_{\text{start}} \leq t \leq t_{\text{stop}}$.

4.1 Initialization

It is feasible to provide automatic initial conditions using the steady-state solution option, by connecting a voltage source in series with the “V controlled” source. Such a source must be present during the steady-state solution and disconnected in the time-domain solution. In the example shown in Figure 1, the cosine voltage source (“V ac” device) has the desired steady-state waveform. In this demonstrative example it is the same as the waveform of the signal `cosin`. The `AC2` source start time is -1 (steady-state presence condition) and the stop time is 1e-15s. It is important to make the stop time much smaller than the integration time-step Δt . When the simulation starts all state-variables are in steady-state.

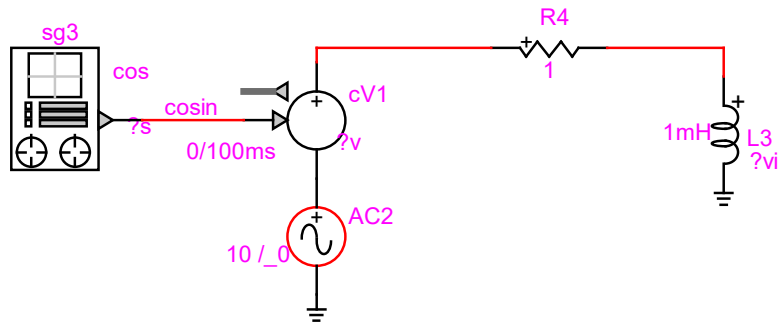

Figure 1 Automatic initialization example